

		DESPIECE	
ID	UDS	DESCRIPCION	MATERIAL
1	1	GANCHO DE IZADO/APERTURA CONTENEDOR	ACERO S-275, GALVANIZADO
2	4	LENGUETA ANTIRRETORNO	EPDM
3	2	LOGO AYUNTAMIENTO	VINILO
4	4	BOCA EXTRAIBLE DE INTRODUCCIÓN DE VIDRIO	EPDM+ ACERO INOX. AISI 304 + PVC
5	2	IDENTIFICACIÓN DEL RESIDUO	VINILO ADHESIVO DE CORTE
6	1	ENVOLVENTE DEL CONTENEDOR	ACERO S-235, LACADO
7	1	EMBELLECEDOR INFERIOR	ACERO INOX. AISI 304, SATINADO
8	4	BOCA EXTRAIBLE ADAPTADA	EPDM+ ACERO INOX. AISI 304 + PVC
9	2	DIFUSOR LED	PMMA + ALUMINIO EXTRUIDO 6063 T5, ANODIZADO
10	2	CERRADURA DE LA PUERTA DEL MUPI	ACERO INOX. AISI 304, SATINADO
11	1	TAPA SUPERIOR	ACERO S-235, LACADO
12	1	CONTENEDOR DE VIDRIO ROTOMOLDEADO	PEAD
13	2	VIDRIO SERIGRAFIADO 1882x1332x6MM	VIDRIO TEMPLADO, SERIGRAFIA RAL 9005
15	1	ESTRUCTURA INTERNA	ACERO S-275, GALVANIZADO
16	1	PUERTA TÉCNICA	ACERO S-235, LACADO

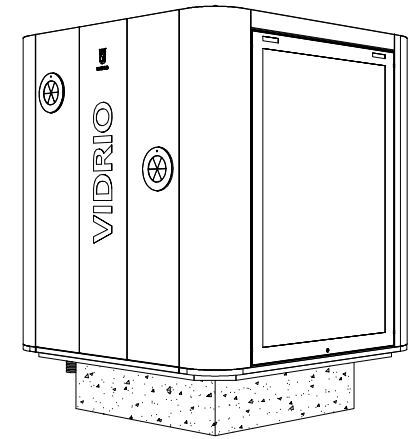

SECCIÓN A-A

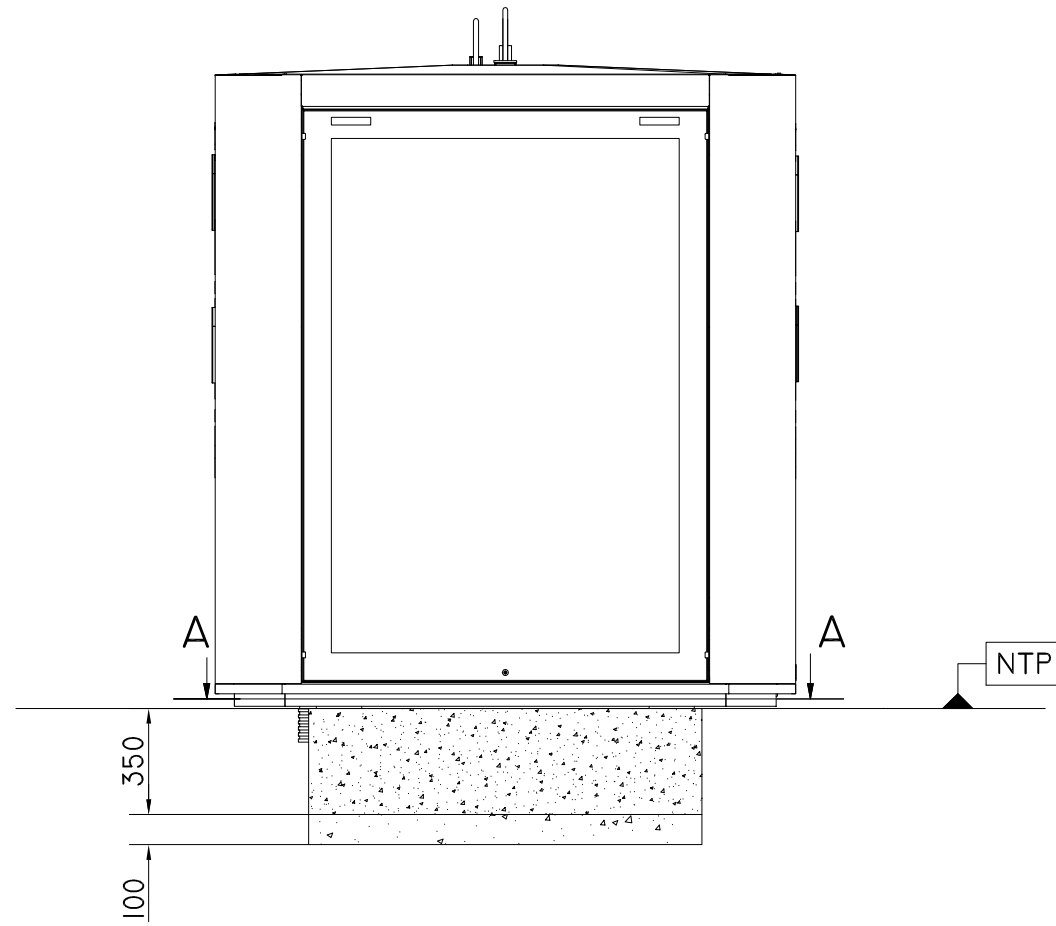
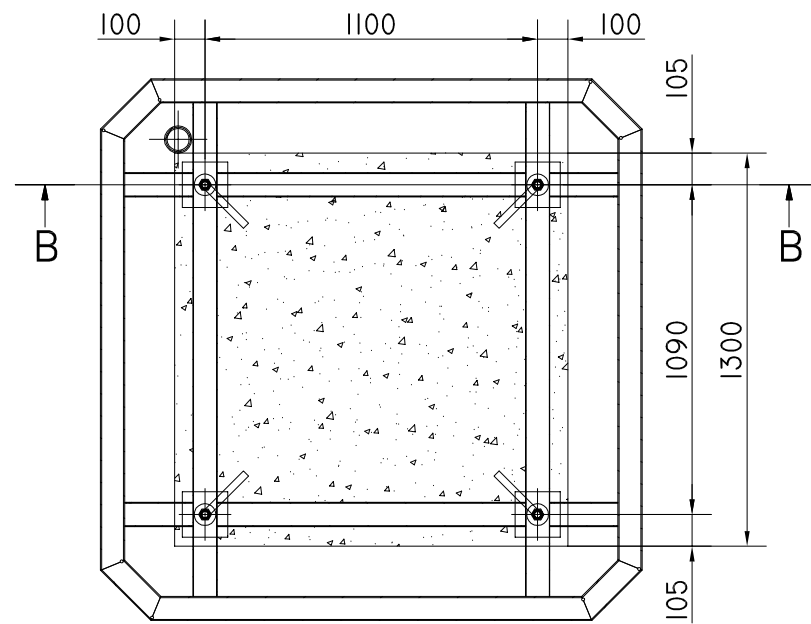

SECCIÓN B-B

